

**Armstrong
& Holmes**

Horse Muck Trailer



- **Designed as a front loading trailer, the front head board folds down over the drawbar, the weight is taken by two tension springs so raising and lowering the ramp requires little effort.**



- **The ramp is clad in non-slip alloy plate.**
- **Front loading ramp enables the trailer to be reversed into a corner out of the way.**
- **To empty the trailer a single piece rear door is hinged sideways and folds back onto the side of the trailer, this prevents the door sticking in the muck heap when tipped.**
- **Hydraulic brakes and a hand brake are standard.**
- **Options include wider tyres and lights.**

Quality

Reliability

Value for Money

Specification

Floor:-	4.5mm steel chequer plate
Sides:-	box section frame clad in 3mm thick plate
Rear door	box section frame clad in 3mm thick plate One piece door swings round to the side of the trailer for tipping
Front door	Box section frame clad in 3mm thick alloy thread plate, Front ramp is spring assisted by Tension Springs.
Top Chassis	125 x 65 channel
Bottom chassis	150 x 75 channel
Axle	60mm solid square section, 1500mm track 6 stud 205 P.C.D. fixing
Brakes	250mm Dia x 60mm wide cam Braked Hydraulic operation from tractor foot brake
Wheels/Tyres	11.5 x 15.3 10 ply tyre on 6 stud rims (11.5 wide x 33" dia)
Hitch	Standard ring hitch for tractor pick-up hitch.
Hydraulic Hose fittings	Tipping pipe ½" B.S.P. Quick Fit (push in type fitting) Brakes standard I.S.O trailer brake coupling
Paint	Standard Colour turquoise Options of Massey Ferguson Red, John Deere Green
Options	Road lighting 400/60 x 15.5 Tyres (16" wide x 33" Dia)

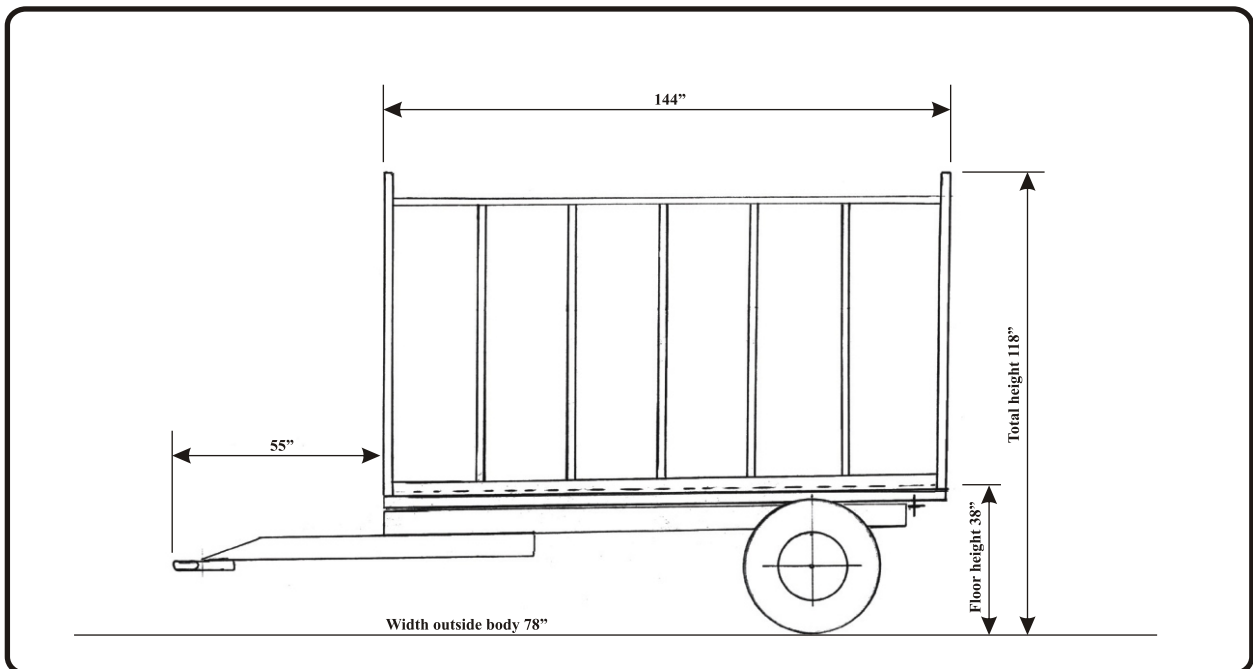

Agricultural Machinery & Equipment Manufacturers

Armstrong & Holmes Ltd.

Fulbeck, Grantham, Lincolnshire

Tel: 01400 261061 Mob: 07802 316 026 Fax: 01400 262289

Email: anne@FarmTrailers.co.uk

www.GrassCareEquipment.co.uk

**Armstrong
& Holmes**